



Presenza

As Meridian's flagship interactive digital signage kiosk, the Presenza provides a seamless combination of form and function. The Presenza is one of Meridian's most popular units, designed to provide an unattended self-service presence for multiple use cases in a variety of industries.



Available Screen Sizes



Landscape and portrait orientation and dual-sided configurations available.

AVAILABLE COMPONENTS

- PC - Solid State Drive, i3, i5, or i7
- Credit Card Payment Terminal
- Rugged Keyboard & Trackball
- WiFi or Cellular Connectivity
- Additional Overhead Display
- 7-Pin Tumbler Lock System
- Thermal Printer
- Laser Printer
- Bill Acceptor
- Barcode Scanner
- Card Dispenser
- Proximity Sensor
- HD Camera

ENCLOSURE CONSTRUCTION

- Durable 14 Gauge Steel Enclosure
- High Quality Powder Coat Finish
- Standard Security Locks, Front Access
- ADA Compliant

POWER

- 120 Volt, 20 AMP Circuit, 50/60 Hz
- Internal Power Strip with Surge Protection
- International Power Conversion Available

POWDER COAT OPTIONS

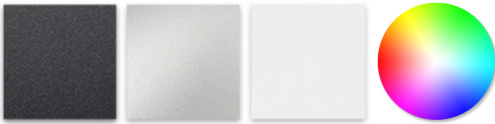

STANDARD INDOOR + OUTDOOR

Black, Silver, Grey Metallic, White, Hammered White

CUSTOM PANTONE MATCHING AVAILABLE



SCREEN

- High Definition LED
- 1920x1080P Resolution*
- 16:9 Aspect Ratio*

**On most screen sizes and models.*

Request specifications for specific screen sizes.

DIMENSIONS (55" UNIT*)

Height: 82.5"

Width: 33.5"

Depth: 6"

Base Plate: 34.5" x 10.8"

Weight: ~450 lbs

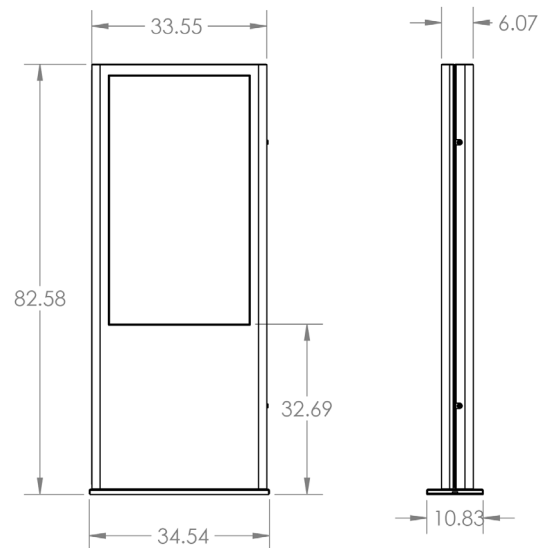

**Dimensions for other screen sizes available upon request*

For More Information

SALES@MZERO.COM | 866 454 6757

A complete end-to-end self-service innovator, Meridian's turn-key solutions are designed and manufactured from our headquarters in North Carolina. By building all of our products from start to finish, we're able to provide greater efficiency and leaner, high-quality products faster than anyone else in the industry.



QUALITY + CERTIFICATION

Meridian promises a level of quality that goes beyond the expected. We control every step of our process from concept to completion, overseeing quality, design, cost and timelines. Many of our products can be UL Listed through UL self-certify and our processes are ISO 9001:2015 certified.

